



Centauri Stars



Using Total Internal Reflection to Detect the Angle of Cherenkov Radiation

Vibeke Andersen, Liam Bonnell, Ryan Griffith, Noah Keene, Jack Mueller-Scott, Ocean Reamer, Merlina Rojas, Dylan Stevens, Natalie Summers, Levi Wicar

Centaurus High School, Lafayette, CO, United States

2026 Beamline for Schools Experiment Proposal

Table of Contents

Introduction.....	2
Background Information.....	2
Cherenkov Radiation.....	2
Refraction and Snell's Law.....	3
Experimental Setup.....	3
Materials.....	3
Experiment.....	4
Data Collection.....	5
What We Hope To Take Away.....	6
Acknowledgments.....	7
References.....	8

Introduction

The Centaurus High School Physics Club in Lafayette, Colorado was created as an opportunity for students from all backgrounds to engage with science. For over 7 years, we have participated in BL4S, gone to JPL for their invention challenge, partnered with Dawn Aerospace and NOAA on an air sampling mission, and undertaken demonstrations in our school and community. We were shortlisted for BL4S in 2019 and 2024 and have been continually improving our detector.

We are fascinated with Cherenkov radiation and its detection. In our experiment, we will determine the angle of Cherenkov radiation using a DIRC detector of our own design.

Background Information

Cherenkov Radiation

The speed of light in a vacuum is the cosmic speed limit. However, within a medium, light's speed is reduced, and the speed of other objects can surpass it. Cherenkov radiation is a phenomenon that occurs when the speed of a charged particle through a dielectric material is greater than the speed of light through the same material. As the charged particle passes through the material it polarizes the molecules in the dielectric, which emit energy in the form of light as they return to their ground state. When the charged particle moves faster than the light does, it causes the wavefronts of the emitted light to overlap, leading to constructive interference that creates a visible wavefront. This light is mainly ultraviolet and at the upper range of the visible spectrum, causing it to appear blue, and is known as Cherenkov radiation. This phenomenon is observed in nuclear reactor cooling pools, as the fission releases high-speed ions through water (Alaeian 2014).

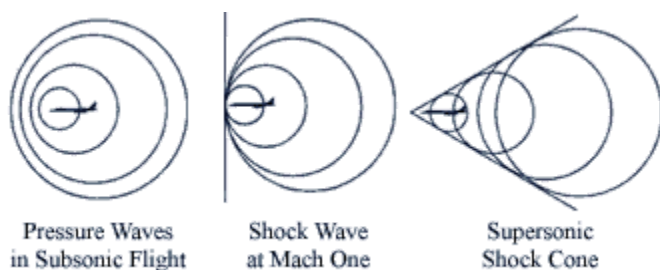

Figure 1. A diagram of a sonic boom created by an aircraft. At high speeds, the sound waves overlap and interfere. Coherent Cherenkov radiation works in a similar way, but with light waves instead of sound. Source: US gov, via Wikimedia Commons

Refraction and Snell's Law

When light moves from one medium to another, it refracts, or changes direction, as described by Snell's law:

$$\frac{\sin(\theta_1)}{\sin(\theta_2)} = \frac{n_2}{n_1}$$

When light is travelling in a medium with a higher refractive index (n_1), approaching a boundary with a material of lower refractive index (n_2), if the incident angle on the boundary is sufficiently shallow, the light will be reflected back into the first material rather than refracting through. The critical angle (θ_{crit}), which is the largest angle for which the light will be experience total internal reflection, is given by:

$$\theta_{crit} = \sin^{-1}\left(\frac{n_2}{n_1}\right)$$

Experimental Setup

Materials

- Silicon Photomultipliers (SiPM) - optimized for the 420 nm wavelength of light (which is within the wavelengths emitted by Cherenkov radiation) - These will be used to make the detector array shown in Fig. 3.
- Flint Glass bar - rectangular prism of flint glass with a high index of refraction. This will be used as the medium for producing the Cherenkov radiation
 - Index of refraction (n) \approx 1.65
 - Thickness (t) = 1.5 cm
 - Width (w) = 1.5 cm
 - Length (L) = 50 cm
- Custom PCB - for analyzing data received by the photomultiplier array

Experiment

We plan to experimentally determine the angle of the Cherenkov radiation produced by a charged particle beam through flint glass by using an array of mini silicon photomultipliers (SiPM). In our experiment, the beam hits the glass at an angle such that the emitted Cherenkov light will totally internally reflect along the glass bar towards the SiPM array (Figure 2). The array and end of the bar will be surrounded by a dark box made out of fabric, to prevent external light coming in. The bar and box will be mounted on a frame, built to allow the box and bar to be moved and rotated in small increments between trials. We can determine which of these photomultiplier tube channels are receiving light, which will allow us to calculate the angle of the Cherenkov radiation. (Schwiening 1998)

The Cherenkov emission angle θ_c can be found with:

$$\theta_c = \cos^{-1}\left(\frac{c}{nv_p}\right)$$

Where c is the speed of light in a vacuum, n is the refractive index of the medium, and v_p is the velocity of the charged particle.

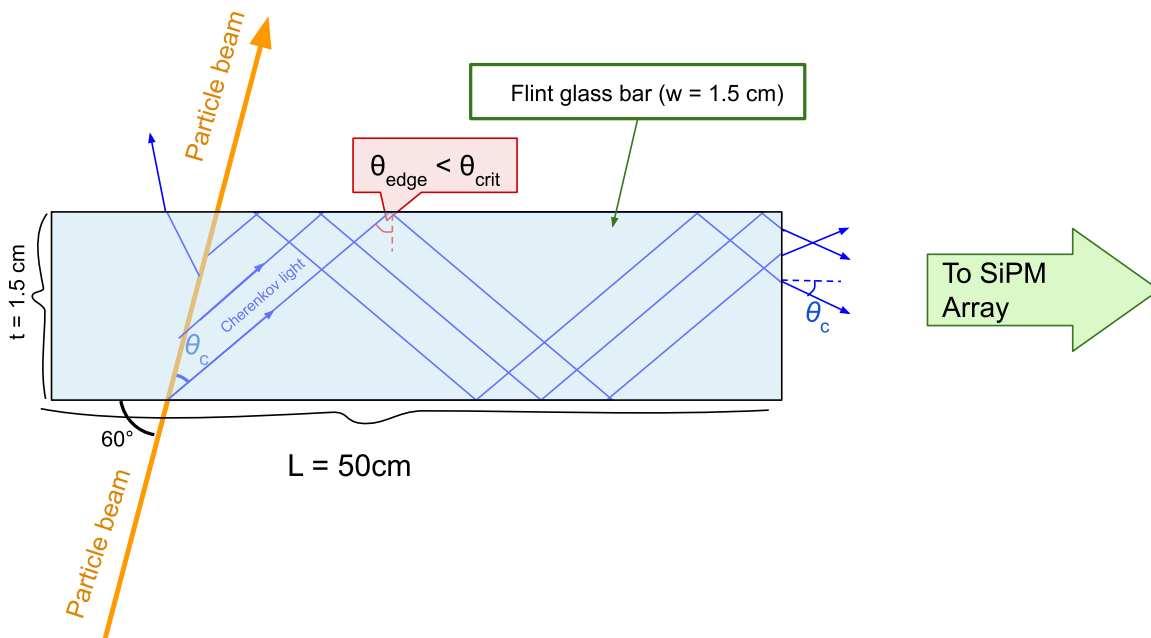

Figure 2. The emitted Cherenkov light is internally reflected in the medium and exits towards the photomultiplier array, with the emission angle preserved. Not to scale.

Substituting $n_1 = 1$ and $n_2 = 1.65$ into the formula for the critical angle we get:

$$\theta_{crit} = \arcsin\left(\frac{1}{1.65}\right) = 37.31^\circ$$

To increase the likelihood that the angle of the light on the inner edge of the glass is shallow enough for total internal reflection to occur, the medium will be placed at a 60° angle relative to the particle beam (Fig 2). Cherenkov light will also be emitted in the opposite direction of the SiPM array, but refract through the edge of the bar.

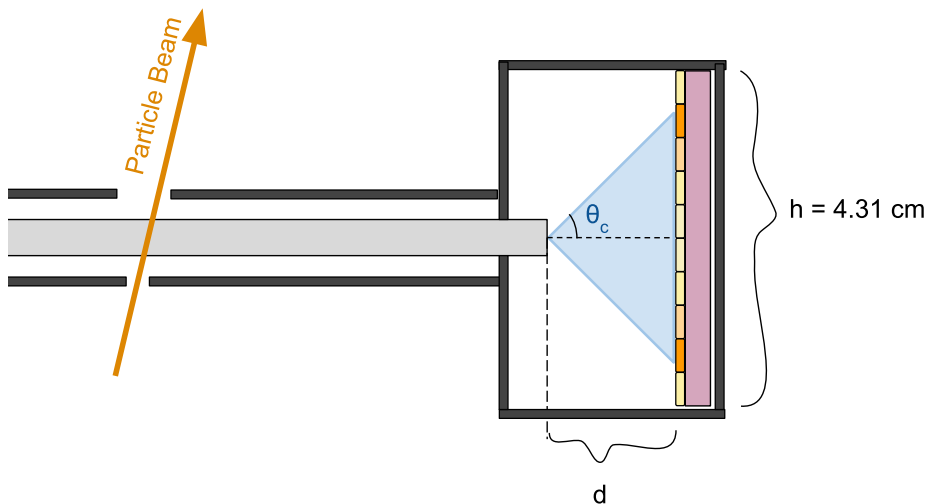

Figure 3. Experimental setup. The orange color in the diagram represents how the SiPMs near the wavefront receive more intense light. Not to scale.

Each SiPM counts how many photons have struck them in a given time. We will determine the location where the maximum amount of light was received, which shows the vertical displacement of the wavefront. The SiPM array is built in a line one wide, for cost-efficiency. Its center is aligned with the bar, for two radius measurements each trial. We will vary the horizontal distance (d) between the SiPM array and the flint glass bar between several measurements. From the data we can construct a 3D representation of the light cone; from this, θ_c can easily be determined geometrically. We will also develop a Geant 4 simulation to create simulated data for comparison.

What We Hope to Take Away

We have and are continuing to learn about how particle accelerators work and the possibility for scientific discovery that they hold. This has been an exciting experience. To read about the little particles that make up everything, on the internet and elsewhere, is one thing, but it is entirely another to be able to discuss, predict, and see their effects firsthand. Most of all, we are grateful for the opportunity to work with some of the brilliant people behind the research, including Dr. Jochen Schwiening, one of the world's leading designers of DIRC detectors.

The members of our club are passionate about physics and we are extremely interested in building careers in the field. This competition gives us a unique opportunity to do innovative experimentation which would set us up with real-world experience and allow us to explore the forefront of science. Additionally, we've been working on our experiment for years and it'd be a dream come true to actually perform it.

Acknowledgments

We would like to thank Kimberly Becker, our physics teacher and mentor, for both getting us away from tangents and fueling them. We would also like to thank Markus Joos, Sune Jakobsen, Jochen Schwiening, Marcel Stanitzki, Oliver DeWolfe, Kenneth Cicere, Robert Carey, Sampa Bhadra, John Cumalat, and Sean Tulin for their help over the years.

References

- Abramowitz, M., Davidson, M. (2016, Feb 12). *Photomultiplier Tubes*. Florida State University. micro.magnet.fsu.edu/primer/digitalimaging/concepts/photomultipliers.html.
- Alaeian, H. (2014, March 15). *An Introduction to Cherenkov Radiation*. Stanford University. large.stanford.edu/courses/2014/ph241/alaeian2/,
- Britannica, The Editors of Encyclopaedia. (2018, Dec 28). Refractive Index. *Encyclopædia Britannica*. Encyclopædia Britannica, Inc. www.britannica.com/science/refractive-index.
- Dryzek, Jerzy, et al. (1970, Jan 1). An Undergraduate Experiment to Test Relativistic Kinematics Using in Flight Positron Annihilation. *American Association of Physics Teachers*. American Association of Physics Teachers. aapt.scitation.org/doi/10.1119/1.2142624.
- Eckhard, J. (2014, May 5). Cherenkov Radiation. *Seminar Elektrodynamik*. Universität Heidelberg. www.thphys.uni-heidelberg.de/~wolschin/eds14_3s.pdf.
- FLP, L., and T. Bir. (1992) Cherenkov Radiation Spectrum. *International Journal of Theoretical Physics*, vol. 31, no. 1, pp. 61–74., doi:10.1007/bf00674341.
- Gruhn, C. R. (1979). The origin of Cherenkov Radiation. *Liquid Scintillation Counting*, 357. Academic Press.
- Nappi, E., & Seguinot, J. (2005). Ring Imaging Cherenkov Detectors: The state of the art and perspectives [PDF]. <https://doi.org/10.1393/ncr/i2006-10004-6>
- Oklahoma State University (2008) Photomultiplier Tubes Part I. *YouTube*, www.youtube.com/watch?v=k4mKDFPiBj8.
- Refraction of Light. (2000) *Refraction of Light*, Hyperphysics hyperphysics.phy-astr.gsu.edu/hbase/geoopt/refr.html.
- Robertson, R, et al. (2009) Optical Imaging of Cherenkov Light Generation from Positron-Emitting Radiotracers. *Physics in Medicine and Biology*, U.S. National Library of Medicine, www.ncbi.nlm.nih.gov/pmc/articles/PMC2765256/.

Saveliev, V. (2010). Silicon Photomultiplier - New Era of Photon Detection. IntechOpen.
<https://doi.org/10.5772/7150>

Schwiening, J. (1998). DIRC, a New Type of Particle Identification System for BaBar. *Nucl. Instrum. Methods Phys. Res.*, 408(1) 211-220.
[https://doi.org/10.1016/S0168-9002\(98\)00245-9](https://doi.org/10.1016/S0168-9002(98)00245-9)

Snell's Law. (2021, July 5). <https://eng.libretexts.org/@go/page/346>